

The Importance of Purpose, Values and Vision

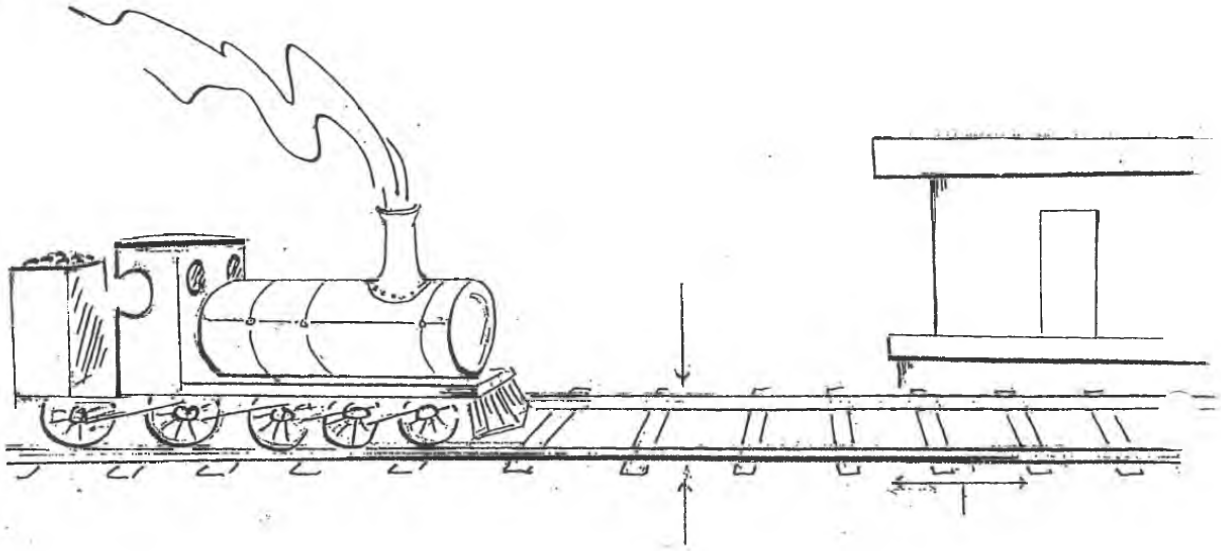

Purpose: *Why we exist*

Values: *The way we operate, the way we do things around here.*

Vision: *Our next destination, a word picture of what we think the future might look like under God.*

Principles

Purpose: *is determined biblically*

Values: *are uncovered not created*

Vision: *is imparted by God, discovered through prayer, & acknowledged by the church body.*

Developing a Purpose Statement

Purpose is why we exist

- Biblically Based
- Usually one sentence
- Over arching rather than specific
- Can be applied to most churches
- It will never go out of date

“A good mission (purpose) must be broad, comprehensive and overarching. It is the primary goal, mandate or charge that is over all over goals.”

Malphurs, *Advanced Strategic Planning*, 105

Developing a Values Statement

Values describes the way we operate

- Values are uncovered not created!
- Are in the DNA of a church
- Are recognised by a “gut reaction” (emotive response)
- Build quite slowly & change very slowly

They may need to be changed if they are unbiblical. This will take time and involves a change in organizational culture.

“The constant, passionate, biblical core beliefs that drive the ministry.”

Malphurs *Advanced Strategic Planning* 83

For reflection: *“Values eat vision for breakfast.”*

Developing a Vision Statement

Vision is our next destination. A word picture of what we think the future might look like (under God)

- Vision is imparted by God, discovered through prayer, & acknowledged by the church Body
- Vision is the specific picture of our future
- Vision typically has a life span of 2 to 5 years

“The mission explains the church’s direction to its people, whereas the vision paints a compelling picture of what that direction will look like.”

Malphurs, *Being Leaders*, 60

Developing a Strategic Plan

Strategic Goals: are the individual goals or steps we must take to reach our vision

Each step should be SMART

- **S**pecific
- **M**easurable
- **A**chievable
- **R**elated to reaching the vision
- **T**imed